



**TECHNICAL MANUAL
GLASSWASHER**

GW-40 BarMaster

Installation, Operation, and Maintenance Instructions

Insinger Machine Company
6245 State Road
Philadelphia, PA 19135-2996

800.344.4802

Fax 215.624.6966

www.insingermachine.com

Thank you for purchasing this quality Insinger product.

On the space provided below please record the model, serial number and start-up date of this unit:

Model: _____

Serial Number: _____

Start-Up Date: _____

When referring to this equipment please have this information available.

Each piece of equipment at Insinger is carefully tested before shipment for proper operation. If the need for service should arise please contact your local Authorized Insinger Service Company.

A Service Network Listing is provided on our web site, www.insingermachine.com or call Insinger at 800-344-4802 for your local authorized servicer.

For proper activation of the *Insinger Limited Warranty* a SureFire™ Start-Up & Check-Out Service should be completed on your machine. Refer to the Introduction section in this manual for an explanation of Insinger SureFire™ Start-Up & Check-Out Program.

Please read the Insinger Limited Warranty and all installation and operation instructions carefully before attempting to install or operate your new Insinger product.

To register your machine for warranty by phone, fax or the internet or for answers to question concerning installation, operation, or service contact our Technical Services Department:

TECHNICAL SERVICE CONTACTS	
Toll-Free	800-344-4802
Fax	215-624-6966
E-mail	service@insingermachine.com
Web	www.insingermachine.com

TABLE OF CONTENTS

<i>Part 1</i>	3-8
<i>Technical Information</i>	
<ul style="list-style-type: none"> • Introduction • Cut-sheets & Installation Drawings • Warranties 	
<i>Part 2</i>	9-10
<i>Installation Instructions and Connection</i>	
<ul style="list-style-type: none"> • Installation and Start-Up Procedures 	
<i>Part 3</i>	11-12
<i>Operating Instructions</i>	
<ul style="list-style-type: none"> • Operating Procedures 	
<i>Part 4</i>	13
<i>Cleaning Instructions/General Maintenance</i>	
<ul style="list-style-type: none"> • Daily and Weekly Procedures • De-liming Procedures 	
<i>Part 5</i>	14-15
<i>Maintenance & Repair Procedures</i>	
<ul style="list-style-type: none"> • Troubleshooting 	
<i>Part 6</i>	
<i>Electrical Schematic & Replacement Parts</i>	
<ul style="list-style-type: none"> • Machine Wiring Diagrams • Replacement Parts 	



GW-40 BarMaster

AUTOMATIC GLASSWASHER

DESIGN

Automatic, chemical sanitizing glasswasher with timed wash and rinse cycles. Fully automatic operation with power on/off button. Capacity is 40- 20"x20" racks per hour. Designed to save energy and water. Quiet operation.

STANDARD EQUIPMENT

- 40 racks per hour
- 1.4 gallon per cycle
- 11" wash clearance
- Electromechanical controls
- Automatic fill, wash, drain, and rinse cycles
- S/S frame, legs and feet
- Door safety switch
- Adjustable bullet feet
- EZ-Clean™ wash and rinse arms
- Multiple cycle selection 90 seconds, 150 seconds
- 110V electrical connection
- Side panels

OTHER SPECIFICATIONS

- Sanitizer required:
 - Sodium Hypochlorite 50 ppm
 - Iodophor 12.5 ppm
- Operating temperatures:
 - 120°F minimum (140°F recommended)

OPTIONAL EQUIPMENT

- Heated maintenance tank to maintain 120°F-140°F water



6245 State Road
Philadelphia, PA 19135-2995
215-624-4800
215-624-6966 FAX
800-344-4802
www.insingermachine.com





GW-40 BarMaster

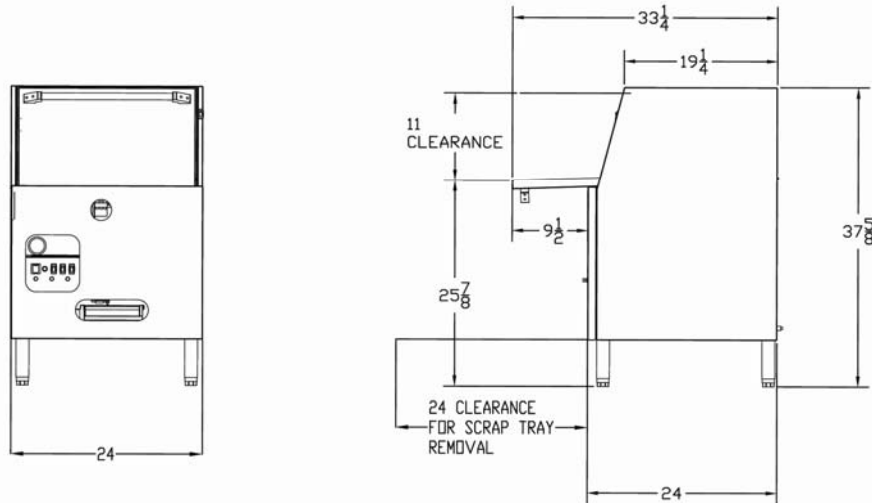

Note: For all rough in connections see Installation and Layout Detail drawing

SPECIFICATIONS

CONSTRUCTION- Hood and tank constructed of type 304 S/S. Hood unit of all welded seamless construction. S/S frame, legs and feet. All internal castings are non-corrosive lead free nickel alloy or bronze.

CONTROLS- Electro-mechanical controls are simple to use and located in a splash proof box.

WASH/RINSE SYSTEM- Rotating lower S/S wash arms. End caps are easily removable for cleaning.

DRAIN SYSTEM- Drain valve externally controlled.

Capacity Per Hour	Tank Capacity	Pump Motor Size	Optional Maintenance Tank	Water Inlet Temperature	Water Usage	Water Requirements
40 racks	1.5 gals	1 hp	1.8 kW	120°F minimum 140°F recommended	1.4 gal./rack 56 gals./hr.	6 gpm max. flow 20-25 psi flow supply
Exhaust Hood Requirement	Time Cycle	Peak Rate Drain Flow	Shipping Weight	Current Draw	Washer with Optional Maintenance Tank	
none	Standard-90 sec. Extreme-150 sec.	9 gals./min.	210 lbs.	115v/1PH/HZ.....	14.0.....	16.0

2/2008 PRINTED IN USA
Information and specifications subject to change without notice.

Available in AutoQuotes and KCL Catalog

INSTALLATION AND LAYOUT DETAIL

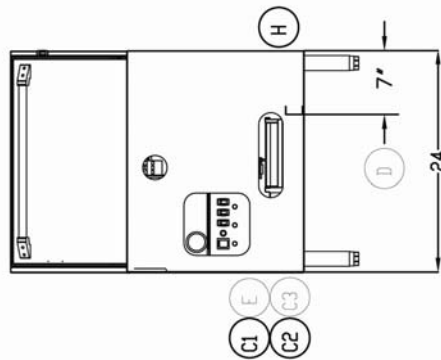
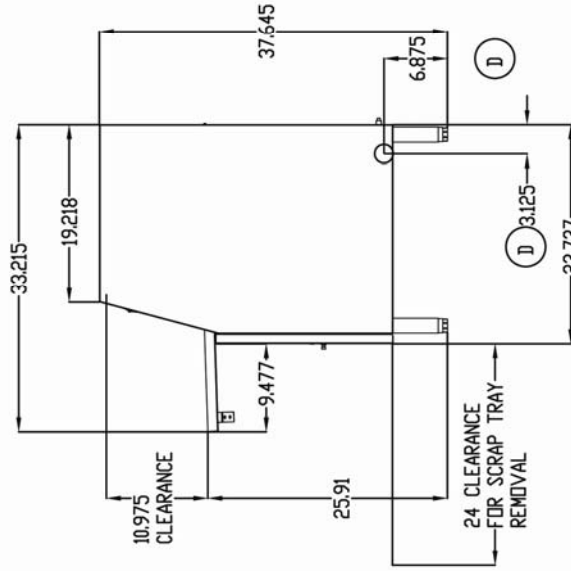

- NOTES:
1. 1/4 GAL/RACK
 2. 56 GAL/HR
 3. 6 GPM FLOW RATE REQUIRED
 4. 20 TO 25 PSI SUPPLY WATER
 5. 9 GPM PEAK DRAIN FLOW
 6. ELECTRIC CORD, WATER HOSE AND CHEMICAL PICKUP TUBES COME OUT THE BOTTOM BACK

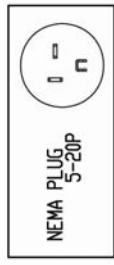

L/TR	DESCRIPTION	SIZE
H	HOT WATER SUPPLY 120F MINIMUM 140F RECOMMENDED	3/4 FIPS 6 FOOT HOSE BACK BOTTOM RIGHT SIDE
D	DRAIN CONNECTION	1-1/2 MIP'S
E	ELECTRICAL SERVICE	115 VOLT 20 AMPS 6 FOOT CORD WITH NEMA 5-20P PLUG
C1	DETERGENT PICKUP TUBE (RED)	1/4" OD TUBE 6 FOOT OUT BACK BOTTOM LEFT SIDE
C2	SANITIZER PICKUP TUBE (WHITE)	1/4" OD TUBE 6 FOOT OUT BACK BOTTOM LEFT SIDE
C3	RINSE/SAID PICKUP TUBE (BLUE)	1/4" OD TUBE 6 FOOT OUT BACK BOTTOM LEFT SIDE

Information and Specifications
Subject to Change Without Notice.

INSINGER IS THE LEADER IN THE MANUFACTURE OF THE PRIMARY INDUSTRY OF THE WORLD. WE ARE NOT A COMPANY AND WE DO NOT MANUFACTURE ANYTHING BUT OUR OWN DESIGN. WE ARE LIMITED TO THE COMPANY OF THIS MANUFACTURER OF A SINGLE OR MANUFACTURER OF A SINGLE OR SYSTEM. ANY VIOLATION OF THE MACHINE COMPANY SHALL BE SUBJECT TO THE PARTY RESPONSIBLE TO APPROPRIATE LEGAL ACTION.

GW-40
GLASSWASHER MACHINE
Philadelphia, PA 19135
(215) 624-4800
FAX (215) 624-6866

Insinger
DRWN: JAB 02.14.08 SCALE 1" = 1'-0"
REV: FILE: STD\GW-40

REV	GW-40
A	

GW-40 BARMASTER GLASSWASHER

INTRODUCTION

Purpose

The purpose of this technical manual is to provide installation, operation, cleaning and maintenance directions.

A section is provided for replacement parts.

Scope

This manual contains all pertinent information to assist in the proper installation, operation, cleaning, maintenance, and parts ordering for the Insinger GW-40 Glasswasher.

The **installation instructions** are intended for qualified equipment installers. The **operation and cleaning instructions** are intended for the daily users of the equipment. The **maintenance and parts sections** are intended for qualified service and/or maintenance technicians. Replacement parts may be ordered directly from our factory or from your local Insinger Authorized Service Agency. You can speak to the **Insinger Technical Services Department, 800/344-4802**, or e-mail us at **service@insingermachine.com**. When calling for warranty information or replacement parts please provide the model and serial number of your Insinger Equipment. These important numbers should be noted in this manual on the spaces provided on the opening page.

Surefire™ Start-up & Check-out Program

Insinger is proud to offer our exclusive Surefire™ Start-up & Check-out Program to our commercial customers. This service is included in the purchase price of your new Insinger dishwasher. We will provide an authorized factory service technician for the initial start-up of your new Insinger dishwasher to ensure it is running at optimum levels from the very first pass. Please call the factory or your local Insinger Sales Representative to schedule this service.

NSF 3-2003 requirements for detergent and chemical sanitizer dispensers.

This machine must be operated with detergent in the integral detergent dispensing system to insure proper washing.

Intended use

The Insinger GW-40 may only be used for cleaning glasses, cups and similar restaurant ware and commercial catering.

Any change in design or use of the glasswasher carried out without the written permission of Insinger, will lead to warranty nullification.

If damage is caused to the glasswasher due to failure to observe the instructions given in this manual, no claims under the warranty agreement can be submitted to Insinger Machine Company.

Safety Instructions

Make sure that you have read and understood the operating instructions before you start to use the glasswasher. The Insinger customer service department can tell you how to operate the washer and how it works.

Definitions

Throughout this guide you will find the following terms: WARNING, CAUTION, & NOTE.

WARNING indicates potential physical danger.
CAUTION indicates potential equipment damage.
NOTE indicates helpful operating hints or tips.

You will visually be able to identify each as shown below:



WARNING:

Indicates potential physical danger.



NOTE:

Indicates helpful operating hints or tips.

CAUTION:

Indicates potential equipment damage.

INSINGER MACHINE COMPANY LIMITED WARRANTY

Insinger Machine Company, Inc. (Insinger) hereby warrants to the original retail purchaser of this Insinger Machine Company, Inc. product, that if it is assembled and operated in accordance with the printed instructions accompanying it, then for a period of either 15 months from the date of shipment from Insinger or 1 year (12 months) from the date of installation or start-up that said Insinger product shall be free from defects in material and workmanship. Whichever one of the two aforesated limited warranty time periods is the shortest shall be the applicable limited warranty coverage time period.

Insinger may require reasonable proof of your date of purchase; therefore, you should retain your copy of invoice or shipping document.

This limited warranty shall be limited to the repair or replacement of parts which prove defective under normal use and service and which on examination shall indicate, to Insinger's satisfaction, they are defective. Any part that is claimed to be defective and covered by this limited warranty must be returned to Insinger, this may be done through an Authorized Service Agency. Furnish serial number of machine with shipment and send to:

*Insinger Machine Company
6245 State Road
Philadelphia, PA 19135-2996*

If Insinger's inspection confirms the defect and the claim, Insinger will repair or replace such part without charge and return it to you freight or postage prepaid.

This limited warranty does not cover any failure or accident, abuse, misuse, alteration, misapplication, improper installation, fire, flood, acts of God or improper maintenance or service, or failure to perform normal and routine maintenance as set out in

the instruction booklet (operating instructions) or for improper operation or failure to follow normal operating instructions (as set out in the instruction booklet). Insinger is not responsible nor liable for any conditions of erosion or corrosion caused by corrosive detergents, acids, lye or other chemicals used in the washing and or cleaning process.

Service must be done by either Insinger Appointed Service Agencies or agencies receiving prior authorization from Insinger.

All warranty work must be done during normal working hours, unless purchaser receives prior authorization from Insinger.

There are no other express warrants except as set forth herein and any applicable implied warranties of merchantability and fitness are limited in duration to the period of coverage of this express written limited warranty. This limited warranty supersedes all other express warranties, implied warranties of merchant-ability and fitness or limited warranties as of this date, January 1, 1998. Some states do not allow limitation on how long an implied warranty lasts so this limitation may not apply to you.

Insinger is not liable for any special, indirect or consequential damages. Some states do not allow the exclusion or limitation of incidental or consequential damages, so this limitation nor exclusion may not apply to you.

Insinger does not authorize any person or company to assume for it any other obligation or liability in connection with the sale, installation, use, removal, return or replacement of its equipment: and no such representations are binding on Insinger.

**INSINGER MACHINE COMPANY LIMITED WARRANTY
COMMERCIAL MARINE USE**

Insinger Machine Company, Inc. (Insinger) hereby warrants to the original retail purchaser of this Insinger Machine Company, Inc. product, that if it is assembled and operated in accordance with the printed instructions accompanying it (installation manual), then for a period of 15 months from the date of installation on board the vessel, that said Insinger product shall be free from defects in material and workmanship.

Insinger may require reasonable proof of your date of equipment install, therefore, you should retain your copy of invoice or shipping document.

This limited warranty shall be limited to the replacement of parts which prove defective under normal use and service and which on examination shall indicate, to Insinger's satisfaction, they are defective. Any part that is claimed to be defective and covered by this limited warranty must be returned to Insinger. Furnish serial number of machine with shipment and send to:

*Insinger Machine Company, Inc.
6245 State Road
Philadelphia, PA 19135-2996*

If Insinger's inspection confirms the defect and the claim, Insinger will repair or replace such part without charge and return it to you freight or post-age prepaid. If part damages are not covered, Insinger will contact the customer and advise.

If a factory trained authorized technician is required to repair or replace defective parts or material during the 18 month warranty period, the cruise line will be responsible for the payment of travel expense and a minimum of four hours labor.

Labor will be billed to the customer at a reduced rate of \$40.00 per hour. If sailing with a vessel is required, then an eight hour per day minimum will apply.

This limited warranty does not cover accident, abuse, misuse, alteration, misapplication, improper installation, fire, flood, or improper maintenance or service, or failure to perform normal and routine maintenance as set out in the instruction booklet (operating instructions) or for improper operation or failure to follow normal operating instructions (as set out in the instruction booklet).

Insinger is not responsible nor liable for any conditions of erosion or corrosion caused by corrosive detergents, acids, lye or other chemicals used in the washing, caring and or cleaning process.

Warranty service must be done by either Insinger Appointed Service Agencies or agencies, customers galley engineers receiving prior authorization from Insinger.

There are no other express warrants except as set forth herein and any applicable implied warranties of merchantability and fitness are limited in duration to the period of coverage of this express written limited warranty. This limited warranty supersedes all other express warranties, implied warranties of merchantability and fitness or limited warranties as the above date.

Insinger does not authorize any person or company locally or overseas to assume for it any other obligation or liability in connection with the sale, installation, use, removal, return or replacement of its equipment; and no such representations are binding on Insinger.

INSTALLATION AND CONNECTION

**WARNING:**

Installation and connection of the washer to the customer's water inlet, waste water drainage and electric connections are to be carried out in accordance with national and local criteria by qualified engineers.

Check for Completeness:

After unpacking the machine, first check the delivery against the packing slip to ensure that it is complete, and inspect for damage that may have occurred during transportation. Immediately report any damage to the carrier, the insurance company and the manufacturer.

Setting Up and Alignment:

When setting up the machine, remember that the machine gives off steam during operation (when you open the door). Protect adjacent wooden furniture to prevent it absorbing moisture and swelling.

CAUTION:

Protect the washer against frost. Systems that carry water can be damaged if they freeze.

The machine must be completely level when installed. Adjust the machine's feet to compensate for any unevenness of the floor.

CAUTION:

Note all the information on the enclosed connection diagram. For the machine to work correctly, the required water pressure and flow rate must be guaranteed at all times.

Connection to the Water Supply:

All plumbing connections must comply with all applicable local, state, and national plumbing codes. Flush the incoming water supply to remove all foreign debris prior to connecting to the unit.

Connect the hot water (120°F minimum) supply hose (1/2" IPS) from the fill solenoid valve located behind the front panel on the right side to the building water supply. Recommended installation includes the use of a ball valve (supplied by others). A pressure regulator (supplied by others) is

Connection to the Water Supply (continued):

required if the water pressure fluctuates or is greater than the recommended pressure (22psig).

The unit has a built in air gap. A vacuum breaker is not required.

Connection to the Drain:

The unit is equipped with a 1-1/2" fpt drain connection and must be connected to drain capable of handling a 9.0 gal/min flow. A proper air gap must be supplied between the unit and the building drain connections. Failure to provide air gap will result in improper or inconsistent draining of unit and potential overflow condition.

Connection to the Power Supply:

Electrical and grounding connections must comply with all applicable portions of the National Electric Code (ANSI/NFPA 70) and/or other electrical codes that may apply.

The unit is 115 volts and the total amp load is 14 fla for the washer without the optional maintenance heater and 16.0 fla for the washer with the optional maintenance heater. The unit is internally wired so that the wash pump and the optional maintenance heater do not operate at the same time.

**WARNING:****Electrical Shock Hazard**

Plug into a grounded 3 prong outlet.

Do not remove ground prong.

Do not use an adapter.

Do not use an extension cord.

Failure to follow these instructions can result in death, fire, or electrical shock.

INSTALLATION AND CONNECTION (continued)

A 120 volt, 60 Hz, AC only, 20 amp, fused electrical supply is required. A time-delay fuse or circuit breaker is recommended. It is recommended that a separate circuit serving only this appliance be provided.

This washer is equipped with a power supply cord having a grounded 3 prong plug.

To minimize possible shock hazard, the cord must be plugged into a mating, grounded 3 prong outlet, grounded in accordance with local codes and ordinances. If a mating outlet is not available, it is the personal responsibility and obligation of the customer to have the properly grounded outlet installed by a qualified electrician.

If codes permit and a separate ground wire is used, it is recommended that a qualified electrician determine that the ground path is adequate.

Do not ground to gas pipe.

Check with a qualified electrician if you are not sure the washer is properly grounded.

Do not have a fuse in the neutral or ground circuit.

Grounding Instructions:

For a grounded, cord-connected washer:

This washer unit must be grounded. In the event of a malfunction or breakdown, grounding will reduce the risk of electrical shock by providing a path of least resistance for electric current. This washer is equipped with a cord having an equipment-grounding conductor and a grounding plug. The plug must be plugged into an appropriate outlet that is properly installed and grounded in accordance with all local codes and ordinances.

**WARNING:**

Improper connection of the equipment-grounding conductor can result in a risk of electrical shock. Check with a qualified electrician or serviceman if you are in doubt as to whether the appliance is properly grounded. Do not modify the plug provided with the appliance— if it will not fit the outlet, have a proper outlet installed by a qualified electrician.

Before using the washer, check that all electrical protection systems are working correctly.

Attention: The machine should not be regarded as isolated from the power supply unless switched off at the customer's main switch or unplugged.

Chemical Connection:

Use a qualified detergent/chemical supplier for your detergent, rinse aid, and sanitizer needs.

The machine is supplied with a chemical dispensing system that is internally wired and ready for use. Position the chemical bottles close to the Glasswasher making sure that they will not be prone to being knocked over or interfere with normal activity around the Glasswasher. Insert the color coded pickup tubes into the correct containers.

The RED tube is for a nonchlorinated, non foaming, commercial detergent recommended for your Glasswasher by your local detergent/chemical supplier.

The CLEAR/WHITE tube is for a chemical sanitizer using a sodium hypochlorite solution or an iodine based sanitizing solution, as recommended by your local detergent/chemical supplier.

The BLUE tube is for a low temperature rinse aid recommended by your local detergent/chemical supplier for the Glasswasher.

A priming push button switch for each of the chemicals is located on the front of the control box. Press and hold the priming switches until the chemical is seen being dispensed into the wash sump.

A speed potentiometer is located on the underneath side of the control box for adjusting the delivery of the chemicals. This adjustment should be left for a qualified person to perform.

Final Tasks:

The washer must be connected to all services (electricity supply and to the fresh water and waste water systems), prior to testing the machine & installation.

OPERATING INSTRUCTIONS

START-UP AND CHECK

Before proceeding with the start up verify the following:

- Open the door and verify that all packaging materials and tie downs have been removed.
- Verify that the pump screen is properly located.
- Verify that the drain stopper is closed and that the linkage is free.
- Check that the plugs are securely screwed into the ends of the wash arms.
- Check that the wash arm is securely screwed into the base and that the arm rotates freely.
- Check that the external scrap screen is installed.
- Check the levels of all chemical containers. Replace if necessary.
- Verify that the incoming voltage is correct.

INSTALLATION START-UP PROCEDURE

- Turn the glasswasher ON/OFF switch to the OFF position.
- Turn the Glasswasher DE-LIME switch to the OFF position.
- Turn the Glasswasher cycle time switch to the STD position.
- Turn the water supply to the unit ON and check for leaks.
- Turn the electric power supply to the glasswasher ON
- Turn the Glasswasher ON/OFF switch to the ON position.
 - The drain will open for a few seconds and then close.
 - The water solenoid valve opens and the glasswasher fills.
 - The cycle light will be on while the fill solenoid is energized.
 - Confirm water supply pressure.
 - After the fill solenoid valve shuts off check the water level.
 - The water level should be at the lowest edge were the back and bottom of the sump meet.

- Press the PRIME switch for the detergent and hold it until there is a detergent dropping into the fill box of the Glasswasher sump.
- Repeat for the Sanitizer and rinse-aid systems.
- With the door closed press the cycle start switch (located near door handle on right side panel of Glasswasher)
- The following occurs:
 - Cycle light comes ON
 - Pump starts for the wash cycle
 - Detergent dispenses into fill box.
 - After wash time is finished
 - Drain opens and water drains into the external scrap screen and goes to the building drain.
 - Drain closes
 - Sump fills with water through the fill box.
 - Sanitizer dispenses into fill box
 - Rinse-Aid dispenses into fill box.
 - After fill cycle is finished
 - Pump starts for the rinse cycle
 - After rinse cycle is finished
 - Cycle light goes OFF.

OPERATING INSTRUCTIONS

**NOTE:**

Pump stops when the door is opened but cycle does not stop.

DE-LIME

- Open the door and remove any glassware rack that may have been left in the washer.
- Manually add to the water in the sump the recommended delime agent recommended by your local detergent/chemical supplier.
- Close the door
- Press the de-lime switch to the ON position.
- The pump will start and continue to operate until the delime switch is pressed to the OFF position.
- The cycle light will be lit while the delime switch is in the ON position.
- After the delime cycle has been performed operate at least one wash cycle without any glassware in the unit.
- Note pump stops when door is opened but cycle does not stop.

MANUAL FILL/DRAIN

- The front of the control panel contains a manual fill and drain switch.
- Pressing this switch to the top position the unit will fill with water.
- Pressing this switch to the bottom position the unit will drain.
- Do not operate a WASH or DELIME cycle after pressing the drain switch.

STD/EXT WASH

- This switch determines the length of the wash cycle.
- STD position uses the standard 90 second cycle.
- EXT position uses the extended 150 second cycle.

ADDING RINSE AID, SANITIZER, & DETERGENT

The machine is supplied with a chemical dispensing system that is internally wired and ready for use. Position the chemical bottles close to the Glasswasher making sure that they will not be prone to being knocked over or interfere with normal activity around the Glasswasher. Insert the color coded pickup tubes into the correct containers.

The RED tube is for a non chlorinated, non foaming, commercial detergent recommended for your Glasswasher by your local detergent/chemical supplier.

The CLEAR/WHITE tube is for a chemical sanitizer using a sodium hypochlorite solution or a iodine based sanitizing solution, as recommended by your local detergent/chemical supplier.

The BLUE tube is for a low temperature rinse aid recommended by your local detergent/chemical supplier for the Glasswasher.

A priming push button switch for each of the chemicals is located on the front of the control box. Press and hold the priming switches until the chemical is seen being dispensed into the wash sump.

A speed potentiometer is located on the underneath side of the control box for adjusting the delivery of the chemicals. This adjustment should be left for a qualified person to perform.

CAUTION:

Only use detergent and rinse aid which are suitable for commercial washers, a non-foaming industrial alkaline detergent.

Do not use any soap intended for a residential dishwasher. This leads to large amounts of foam building up in the washer and will void your manufacturers warranty.

CAUTION:

Detergents for commercial dishwashers cause corrosion. Always follow the instructions on the packaging and drums.

CAUTION:

Do not mix different detergent products, this could cause the dosing pump to break down due to crystallization.

CLEANING/GENERAL MAINTENANCE

Daily Cleaning:

At the end of each day, or 8 hours

- Drain the machine by depressing the manual drain switch.
- After the unit has drained, turn the power switch to the off position.
- Open the door and remove the lower spray arm by unscrewing the knurled fastener.
- Inspect the spray nozzles to make sure that they are free of any debris that could affect their spray patterns.
- Remove the end caps from the spray manifold and clean with the brush provided. Do not strike the manifold against solid objects. Flush the manifold with water.
- Remove and clean the pump intake screen.
- Clean the inside of the wash tank with clean water.
- Remove the scrap tray carefully from the drain sump to avoid any waste particles from falling into the drain sump. Empty any waste particles into an approved waste receptacle. Back flush the scrap tray until it is clean. Do not strike the scrap tray against solid objects.
- Thoroughly clean the interior of the drain sump.
- Check the levels of the chemical containers and replace as needed. When replacing chemical containers it may be necessary to prime the pumps by using the prime buttons.
- Replace the scrap tray.
- Replace the pump intake screen.
- Replace the manifold end caps.
- Replace the manifold and screw in the knurled fastener. Confirm that the manifold is free rotating.
- Leave the door open overnight to allow drying.

De-liming:

Machines that are operated in hard water areas and are not connected to an external water treatment system must be de-limed from time to time. There are de-liming agents specially designed for commercial dishwasher available for this purpose. Please consult your detergent supplier.

CAUTION:

De-liming agents for commercial dishwashers cause corrosion. Always follow the instructions for use and safety instructions on the packaging and drums.

De-liming solutions or other acids must not come in contact with household bleach (sodium hypochlorite) or any chemicals containing chlorine, iodine, bromine, or fluorine. Mixing will cause hazardous gases to form. Skin contact with de-liming solutions can cause severe irritation and possible chemical burns. Consult your chemical supplier for specific safety precautions.

**NOTE:**

Clean the scrap tray after every use period or more frequently during heavy usage times.

Do not allow the scrap tray to become clogged with soil or waste particles.

TROUBLESHOOTING
Faults where it is *not necessary* to call Insinger.

You can rectify minor faults yourself following the steps described in the table below. If you are unable to rectify the fault, contact Insinger service (1-800-344-4802.)

Do not open any panels or expose any parts of the machine if tools are necessary to do so. Risk of electric shock.

Work on the electrical equipment should only be performed by service personnel. First disconnect the washer from the main power. Do not switch the washer on again until the cause of the fault has been identified.

WARNING:

Turn off the main switch on the dishwasher so it is isolated from the power supply.

Before calling for service on your Glasswasher please check that:

- Wash arms are clean and free to rotate.
- Scrap screen is properly positioned and clean.
- Sanitizer, detergent and rinse aid bottles have an adequate level.
- All plumbing valves are open.
- Electrical power to unit is ON.

<i>Problem</i>	<i>Cause</i>	<i>Remedy</i>
Machine will not start	No Power (Power light off) Tripped circuit breaker Door not closed Start switch not depressed long enough Defective door switch Defective start switch	Check power source Reset breaker in customer breaker panel Close door fully. Hold start switch for 3 seconds Check and replace if necessary Check and replace if necessary
Low or no water	Main water supply is turned off Drain valve not seated and open	Turn on water supply Seat drain valve. Check for foreign matter on drain seat
Machine will not fill Low or no water	Closed water supply valve Plugged line strainer Drain valve open Defective fill valve Defective Timer	Open valve Remove and clean screen Check seat for food particles Check and replace if necessary Check and replace if necessary
Water leaking out the door	Spray arms not rotating Spray arm clean out caps not in place or loose No dish rack in machine	Remove and clean arm, shaft, and bushing Reinstall caps and hand tighten Place rack in machine
Machine overfills Fill level is to bottom edge of back wall. Do not under fill	Supply water pressure too high Defective fill valve Defective drain solenoid Defective timer	Adjust supply water pressure to 22 -24 psig Check and replace as necessary Check and replace as necessary. Check and replace as necessary
Scrap trap overflowing	Scrap screen full Scrap tray screen plugged Scrap tray tank drain line plugged Check water level for over filling	Must be kept clean and in place Clean scrap tray screen Clean out drain line Adjust water level
Water temperature is too low when in use.	Incoming water temperature at machine too low	Raise temperature of incoming water to machine. (120° F min 140°F recommended)

TROUBLESHOOTING

<i>Problem</i>	<i>Cause</i>	<i>Remedy</i>
Poor washing results	Clogged spray nozzles and dirty sump tank Spray arm not revolving Low water level Poor water conditions Detergent container empty Detergent setting to low Wash water temperature too low Ware being improperly placed in rack Improperly cleaned equipment	Clean wash arm and unit Remove and clean arm, shaft, and bushing Adjust fill to proper level Have filter or softener installed Fill container Contact detergent supplier Check incoming water temperature Use proper racks do not overload racks Clean and delime
Glasses slimy or soapy at end of cycle	Sanitizer feed line in detergent container Improper Rinse Aid setting	Clean line and place in proper container Adjust chemical setting
Insufficient pumped spray pressure	Clogged spray arm Partially plugged pump inlet screen	Clean spray arm and nozzles Clean pump inlet screen
Detergent, sanitizer, and/or Rinse Aid not feeding properly	Chemical container is empty Feed tubes to/from pumps clogged Tubing kinked or split Feed lines will not fill	Refill or replace container(s) Clean obstruction and flush with hot water or replace tubing Straighten or replace tubing Replace defective parts: Note the detergent, sanitizer, or Rinse Aid advances in the line on each rotation of the pump. The product should hold position when the pump is off. If the product falls back toward the supply one or more of the following may exist. Debris in the pump Split feed line Bad pump tube Replace parts as necessary.



Detergent, Sanitizer and Rinse-aid pump squeeze tube replacement. Design eliminates the need for tools and enables easy cap removal and tube replacement.

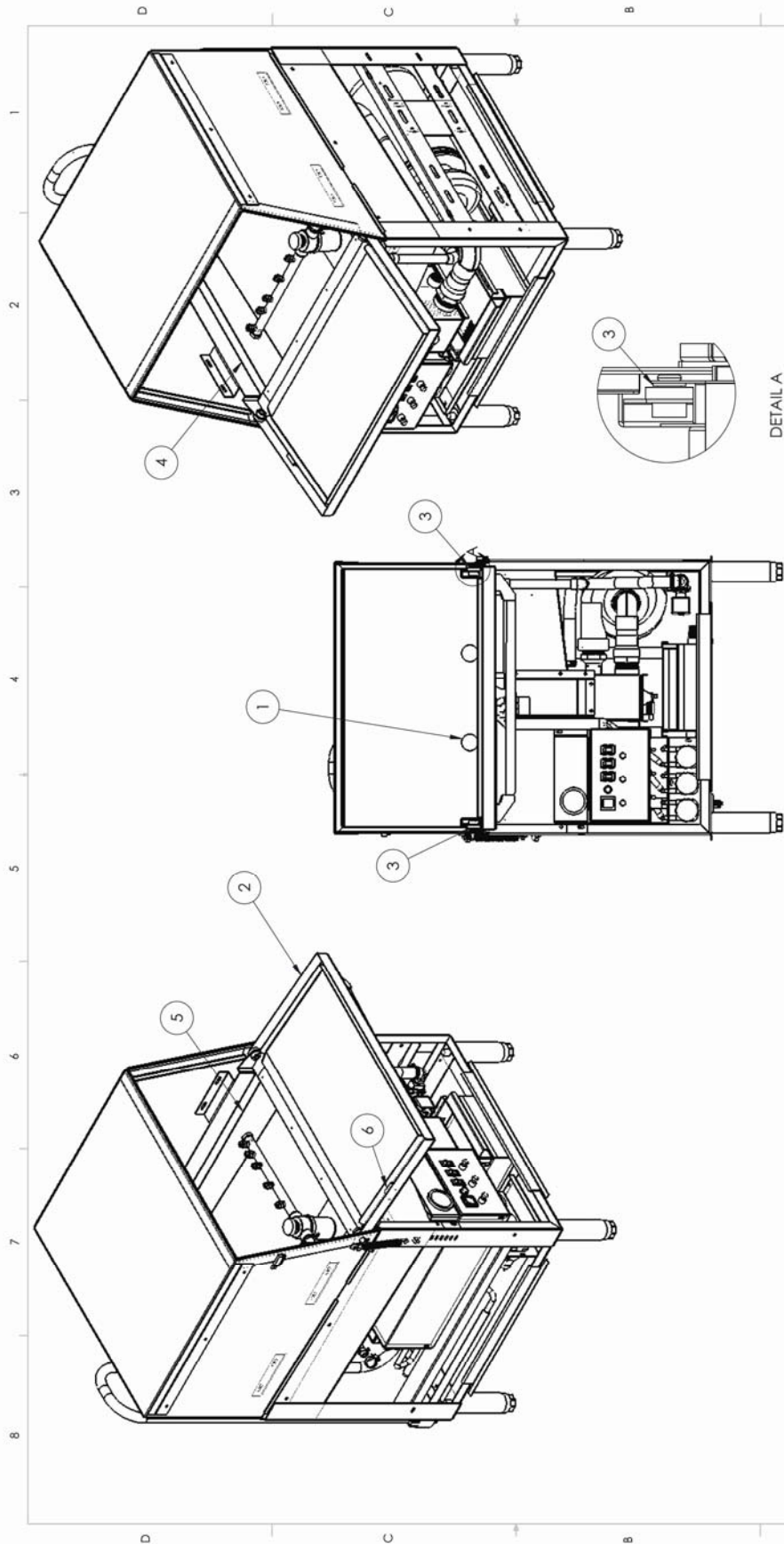

DETAIL A
SCALE 1:2

<p>THE INFORMATION ON THIS DRAWING IS THE PROPERTY OF INSINGER. IT SHALL NOT BE REPRODUCED OR TRANSMITTED IN ANY FORM OR BY ANY MEANS, ELECTRONIC OR MECHANICAL, INCLUDING PHOTOCOPYING, RECORDING, OR BY ANY INFORMATION STORAGE AND RETRIEVAL SYSTEM. ANY PART, COMPONENT OR SYSTEM, OR ANY INFORMATION CONTAINED HEREIN IS THE PROPRIETARY RIGHTS OF INSINGER. ANY REPRODUCTION OR TRANSMISSION OF THIS INFORMATION SHALL BE SUBJECT TO APPROPRIATE LEGAL ACTION.</p>	<p>REV: ECN NO: DATE: FILE: B</p>	<p>REV: ECN NO: DATE: FILE: B</p>	<p>UNLESS OTHERWISE SPECIFIED</p>	<p>TOLERANCES</p> <p>FRACTIONS ±1/64</p> <p>DECIMALS XXX ±.005</p> <p>XX ±.01</p> <p>ANGLES ±1/2°</p>	<p>GW-40 DOOR ASSY</p>	<p>FINISH: -</p>	<p>REQ'D</p>	<p>NEXT ASSY</p>	<p>DWG. NO. GW-40 PARTS-2</p>
--	-----------------------------------	-----------------------------------	-----------------------------------	---	------------------------	------------------	--------------	------------------	-------------------------------

Philadelphia, PA 19135
(215) 624-4800
FAX (215) 624-6966



ITEM NO.	PART NO.	DESCRIPTION	QTY.
6	DE9-280	MAGNET	1
5	1556-25	RIGHT SLIDE RAIL WELD	1
4	1556-24	LEFT SIDE RAIL WELD	1
3	D3081	BUSHING BEARING	2
2	1556-31	ACCESS DOOR WELD	1
1	D2-584A	KNOB	2

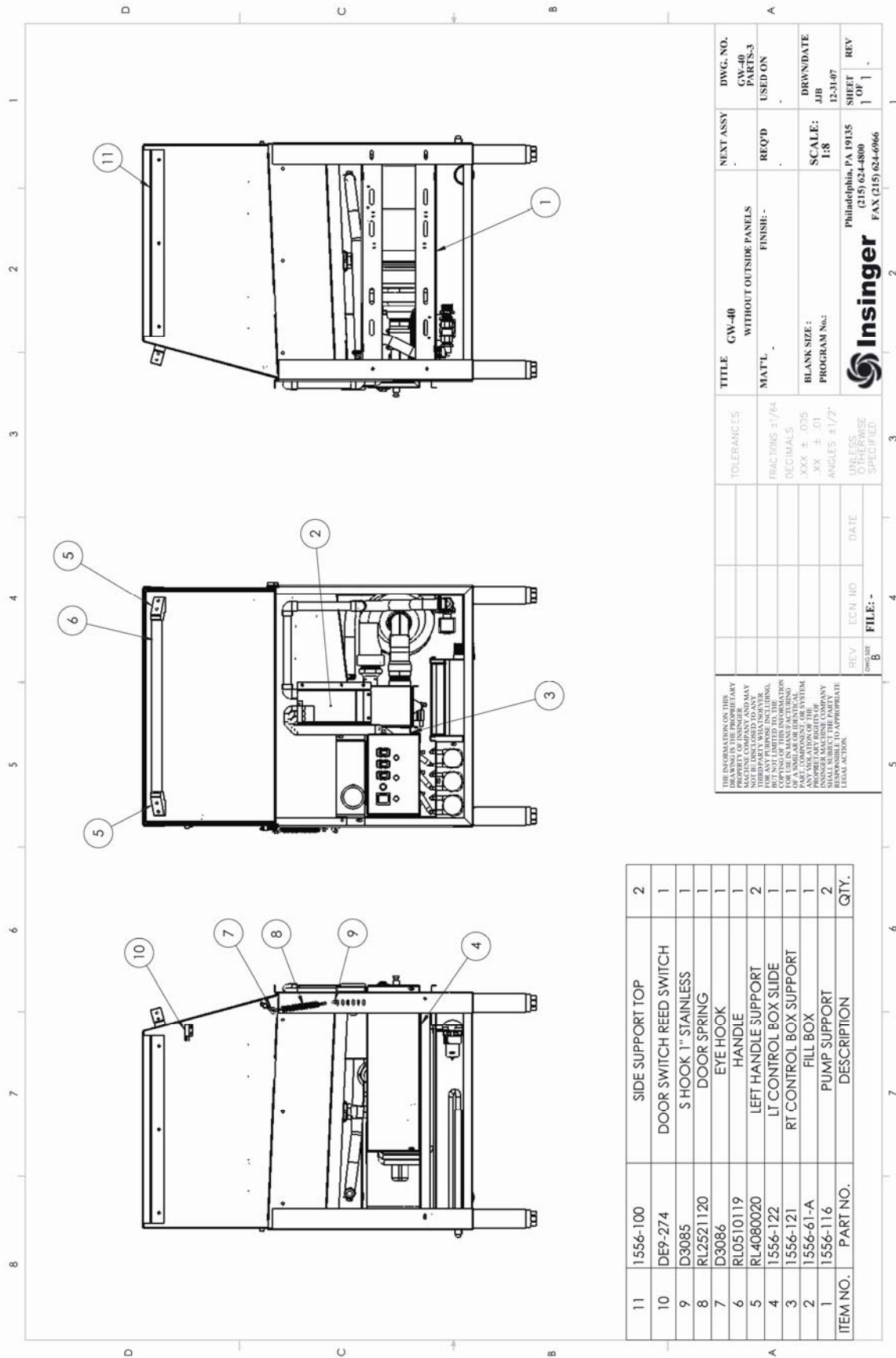

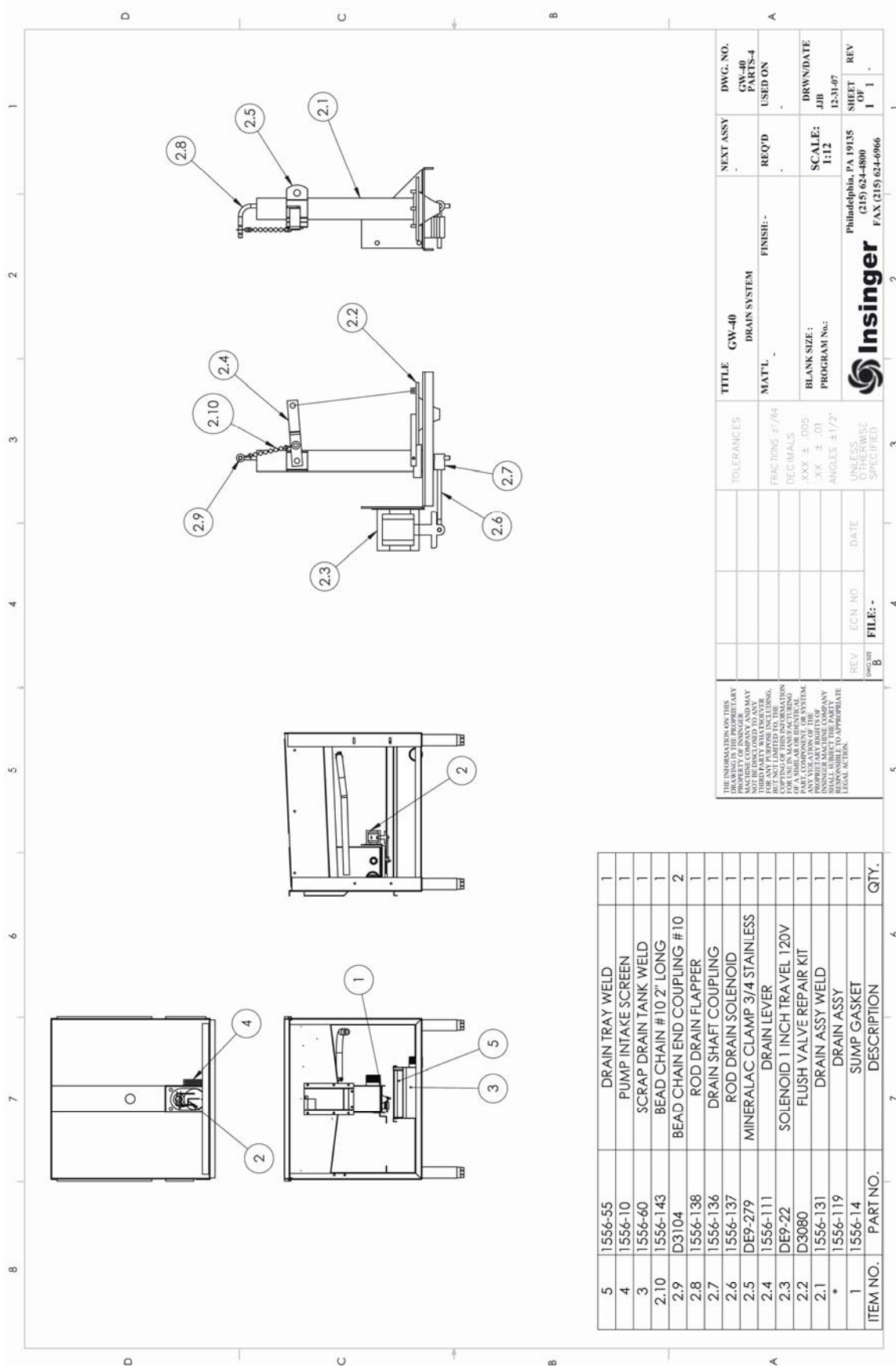

ITEM NO.	PART NO.	DESCRIPTION	QTY.
5	1556-55	DRAIN TRAY WELD	1
4	1556-10	PUMP INTAKE SCREEN	1
3	1556-60	SCRAP DRAIN TANK WELD	1
2.10	1556-143	BEAD CHAIN #10 2' LONG	1
2.9	D3104	BEAD CHAIN END COUPLING #10	2
2.8	1556-138	ROD DRAIN FLAPPER	1
2.7	1556-136	DRAIN SHAFT COUPLING	1
2.6	1556-137	ROD DRAIN SOLENOID	1
2.5	DE9-279	MINERALAC CLAMP 3/4 STAINLESS	1
2.4	1556-111	DRAIN LEVER	1
2.3	DE9-22	SOLENOID 1 INCH TRAVEL 120V	1
2.2	D3080	FLUSH VALVE REPAIR KIT	1
2.1	1556-131	DRAIN ASSY WELD	1
*	1556-119	DRAIN ASSY	1
1	1556-14	SUMP GASKET	1

<p>THE INFORMATION ON THIS DRAWING IS THE PROPRIETARY PROPERTY OF INSINGER MACHINE COMPANY AND MAY BE REPRODUCED OR TRANSMITTED IN ANY FORM OR BY ANY MEANS, BUT NOT LIMITED TO, ELECTRONIC OR MECHANICAL, INCLUDING PHOTOCOPYING, RECORDING, OR BY ANY INFORMATION STORAGE AND RETRIEVAL SYSTEM. INSINGER MACHINE COMPANY IS NOT RESPONSIBLE FOR ANY LEGAL ACTION.</p>	<p>REV: B DATE: FILE: -</p>	<p>ECN NO: DATE: FILE: -</p>	<p>TOLERANCES: FRACTIONS ±1/4 DECIMALS XXX ± .005 .XX ± .01 ANGLES ±1/2° UNLESS OTHERWISE SPECIFIED</p>	<p>TITLE: GW-40 DRAIN SYSTEM</p>	<p>FINISH: -</p>	<p>REQ'D</p>	<p>NEXT ASSY</p>	<p>DWG. NO. GW-40 PARTS-4 USED ON</p>	<p>DRWN/DATE JOB 12-31-97</p>	<p>REV SHEET OF 1 1</p>
---	---------------------------------	------------------------------	---	--------------------------------------	------------------	--------------	------------------	---------------------------------------	---------------------------------------	-------------------------



Philadelphia, PA 19135
(215) 624-4800
FAX (215) 624-6966

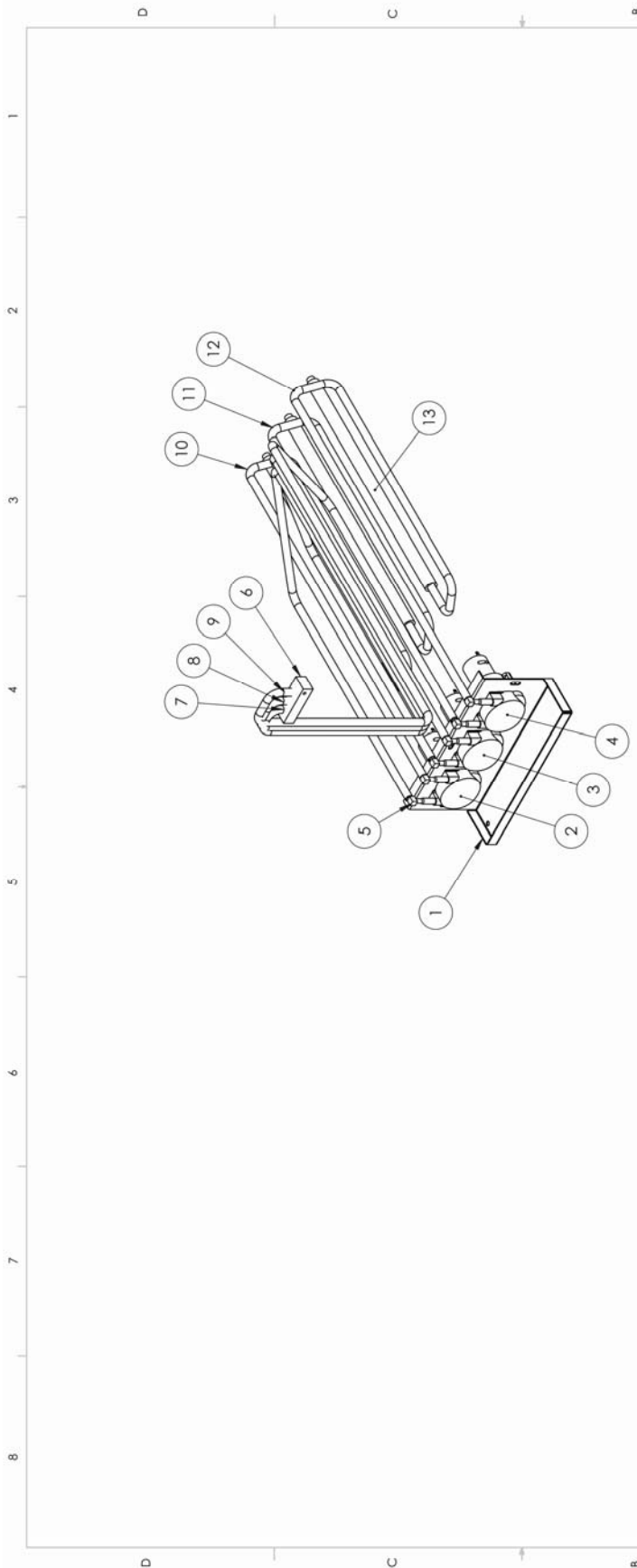

ITEM NO.	PART NO.	DESCRIPTION	QTY.
D3115		REPLACEMENT SQUEEZE TUBE FOR PUMP (ORDER 1 FOR EACH PUMP)	
13	D207K-B4-48	1 GAL BOTTLE INSERT TUBE	3
12	D3095-6FT	RINSE AID TUBE BLUE 6FEET	1
11	D3096-6FT	SANITIZER TUBE WHITE 6FEET	1
10	D3094-6FT	DETERGENT TUBE RED 6FEET	1
9	D3095-3FT	RINSE AID TUBE BLUE 3FEET	1
8	D3096-3FT	SANITIZER TUBE WHITE 3FT	1
7	D3094-3FT	DETERGENT TUBE RED 3FEET	1
6	1556-132	DISPENSER BLOCK	1
5	D3093	90 ELL TUBING POLYETHYLENE	6
4	D3089	PUMP RINSE AID BLUE	1
3	D3090	PUMP SANITIZER CLEAR	1
2	D3091	PUMP DETERGENT RED	1
1	1556-94	PUMP MOUNT	1
		DESCRIPTION	

THE INFORMATION ON THIS DRAWING IS THE PROPRIETARY PROPERTY OF INSINGER MACHINE COMPANY AND MAY BE REPRODUCED OR TRANSMITTED IN ANY FORM OR BY ANY MEANS, BUT NOT LIMITED TO, ELECTRONIC OR MECHANICAL, INCLUDING PHOTOCOPYING, RECORDING, OR BY ANY INFORMATION STORAGE AND RETRIEVAL SYSTEM, WITHOUT THE WRITTEN PERMISSION OF INSINGER MACHINE COMPANY. INSINGER MACHINE COMPANY ASSUMES NO LIABILITY FOR DAMAGES OF ANY KIND ARISING FROM THE USE OF THIS DRAWING.		TOLERANCES FRACTIONS: ±1/64 DECIMALS .XXX ± .005 .XX ± .01 ANGLES ±1/2° UNLESS OTHERWISE SPECIFIED	TITLE: GW-40 CHEMICAL FEED SYSTEM FINISH:- MAT'L:	NEXT ASSY: REQ'D DWG. NO.: GW-40 PARTS-7 USED ON:
REV: B DATE:	ECH: NO FILE: -	SCALE: 1:4 PROGRAM NO:	DRWN/DATE: JJB 12-31-07 SHEET 1 OF 1 REV:	
Philadelphia, PA 19135 (215) 624-4800 FAX (215) 624-6966				

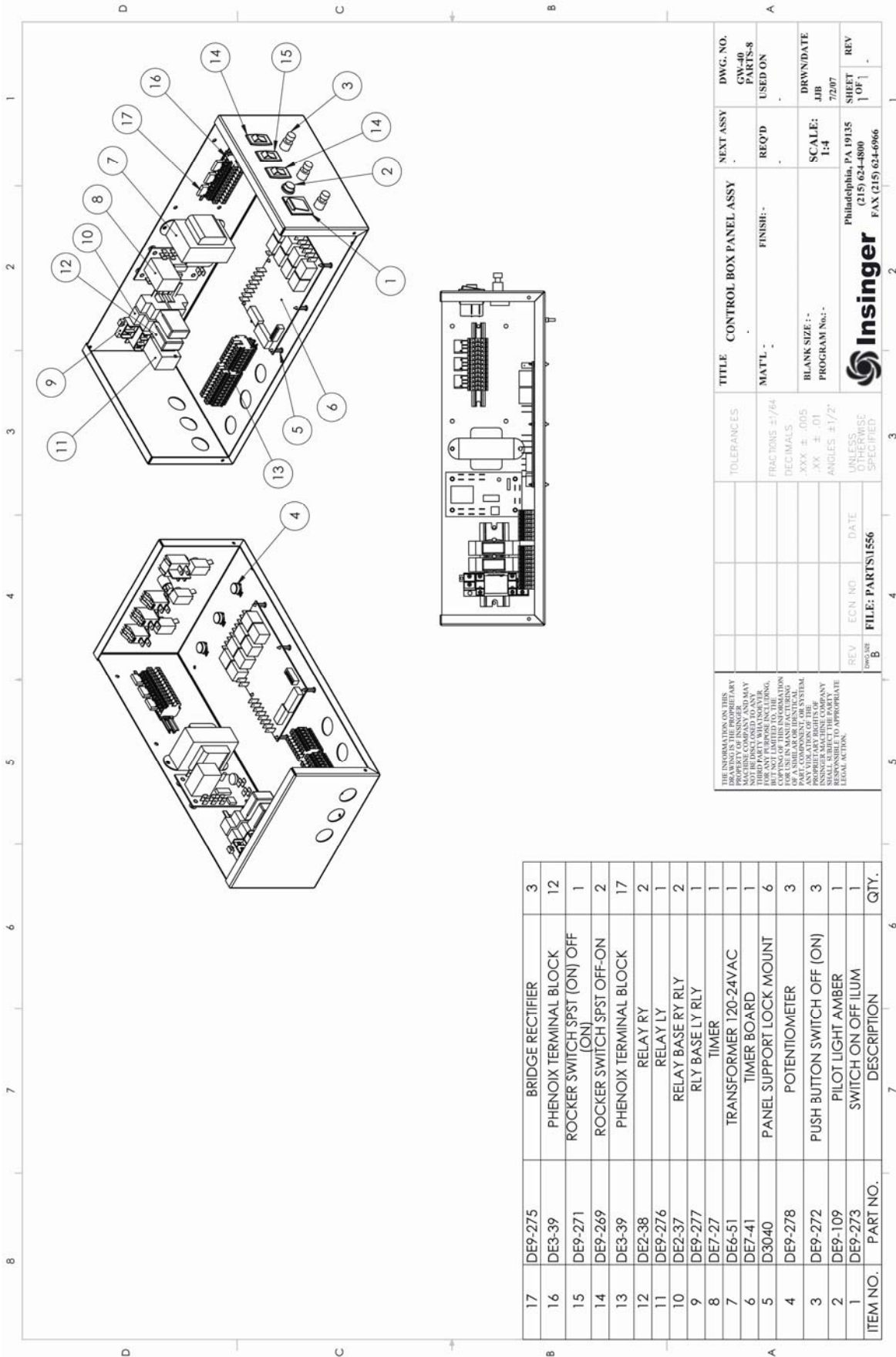

ITEM NO.	PART NO.	DESCRIPTION	QTY.
17	DE9-275	BRIDGE RECTIFIER	3
16	DE3-39	PHENOX TERMINAL BLOCK	12
15	DE9-271	ROCKER SWITCH SPST (ON) OFF (ON)	1
14	DE9-269	ROCKER SWITCH SPST OFF-ON	2
13	DE3-39	PHENOX TERMINAL BLOCK	17
12	DE2-38	RELAY RY	2
11	DE9-276	RELAY LY	1
10	DE2-37	RELAY BASE RY RLY	2
9	DE9-277	RLY BASE LY RLY	1
8	DE7-27	TIMER	1
7	DE6-51	TRANSFORMER 120-24VAC	1
6	DE7-41	TIMER BOARD	1
5	D3040	PANEL SUPPORT LOCK MOUNT	6
4	DE9-278	POTENTIOMETER	3
3	DE9-272	PUSH BUTTON SWITCH OFF (ON)	3
2	DE9-109	PILOT LIGHT AMBER	1
1	DE9-273	SWITCH ON OFF ILLUM	1
		DESCRIPTION	

TITLE		CONTROL BOX PANEL ASSY	NEXT ASSY	DWG. NO.
MATERIAL		FINISH:-	REQ'D	GW-48 PARTS-8 USED ON
TOLERANCES		FRAC TIONS ±1/64		
		DECIMALS		
		.XXX ± .005		
		.XX ± .01		
		ANGLES ±1/2°		
REV	ECN NO	DATE	UNLESS OTHERWISE SPECIFIED	DRWN/DATE
B			FILE: PARTS1556	JJB 7/20/07
			Philadelphia, PA 19135	SHEET
			(215) 624-4800	1 OF 1
			FAX (215) 624-6966	REV



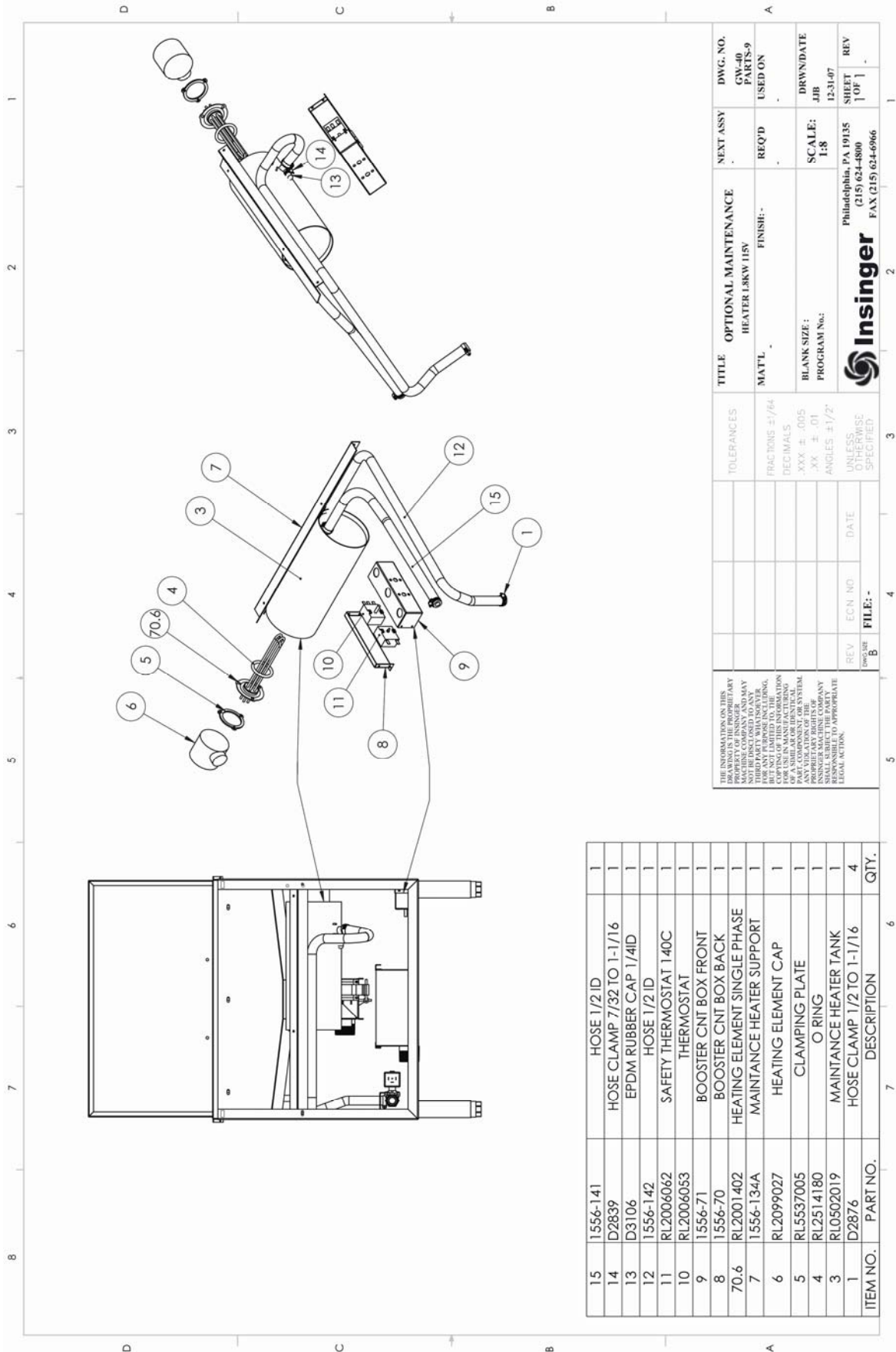

ITEM NO.	PART NO.	DESCRIPTION	QTY.
15	1556-141	HOSE 1/2 ID	1
14	D2839	HOSE CLAMP 7/32 TO 1-1/16	1
13	D3106	EPDM RUBBER CAP 1/4ID	1
12	1556-142	HOSE 1/2 ID	1
11	RL2006062	SAFETY THERMOSTAT 140C	1
10	RL2006053	THERMOSTAT	1
9	1556-71	BOOSTER CNT BOX FRONT	1
8	1556-70	BOOSTER CNT BOX BACK	1
70.6	RL2001402	HEATING ELEMENT SINGLE PHASE	1
7	1556-134A	MAINTANCE HEATER SUPPORT	1
6	RL2099027	HEATING ELEMENT CAP	1
5	RL5537005	CLAMPING PLATE	1
4	RL2514180	O RING	1
3	RL0502019	MAINTANCE HEATER TANK	1
1	D2876	HOSE CLAMP 1/2 TO 1-1/16	4
ITEM NO.	PART NO.	DESCRIPTION	QTY.

<small>THE INFORMATION ON THIS DRAWING IS THE PROPERTY OF INSINGER MACHINE COMPANY AND MAY NOT BE REPRODUCED OR TRANSMITTED IN ANY FORM OR BY ANY MEANS, ELECTRONIC OR MECHANICAL, INCLUDING PHOTOCOPYING, RECORDING, OR BY ANY INFORMATION STORAGE AND RETRIEVAL SYSTEM. WITHOUT THE WRITTEN PERMISSION OF INSINGER MACHINE COMPANY, NO PART OF THIS DRAWING IS TO BE REPRODUCED OR TRANSMITTED IN ANY FORM OR BY ANY MEANS, ELECTRONIC OR MECHANICAL, INCLUDING PHOTOCOPYING, RECORDING, OR BY ANY INFORMATION STORAGE AND RETRIEVAL SYSTEM.</small>	REV	ECN NO.	DATE
	B	FILE:-	
TOLERANCES FRACTIONS ±/64 DECIMALS .XXX ±.005 .XX ±.01 ANGLES ±1/2° UNLESS OTHERWISE SPECIFIED	TITLE MAT'L FINISH:-	NEXT ASSY REQ'D	DWG. NO. GW-40 PARTS-9 USED ON
Philadelphia, PA 19135 (215) 624-4800 FAX (215) 624-6966	SCALE: 1:8 PROGRAM No.:	DRWN/DATE JJB 12-31-07	SHEET 1 OF 1 REV

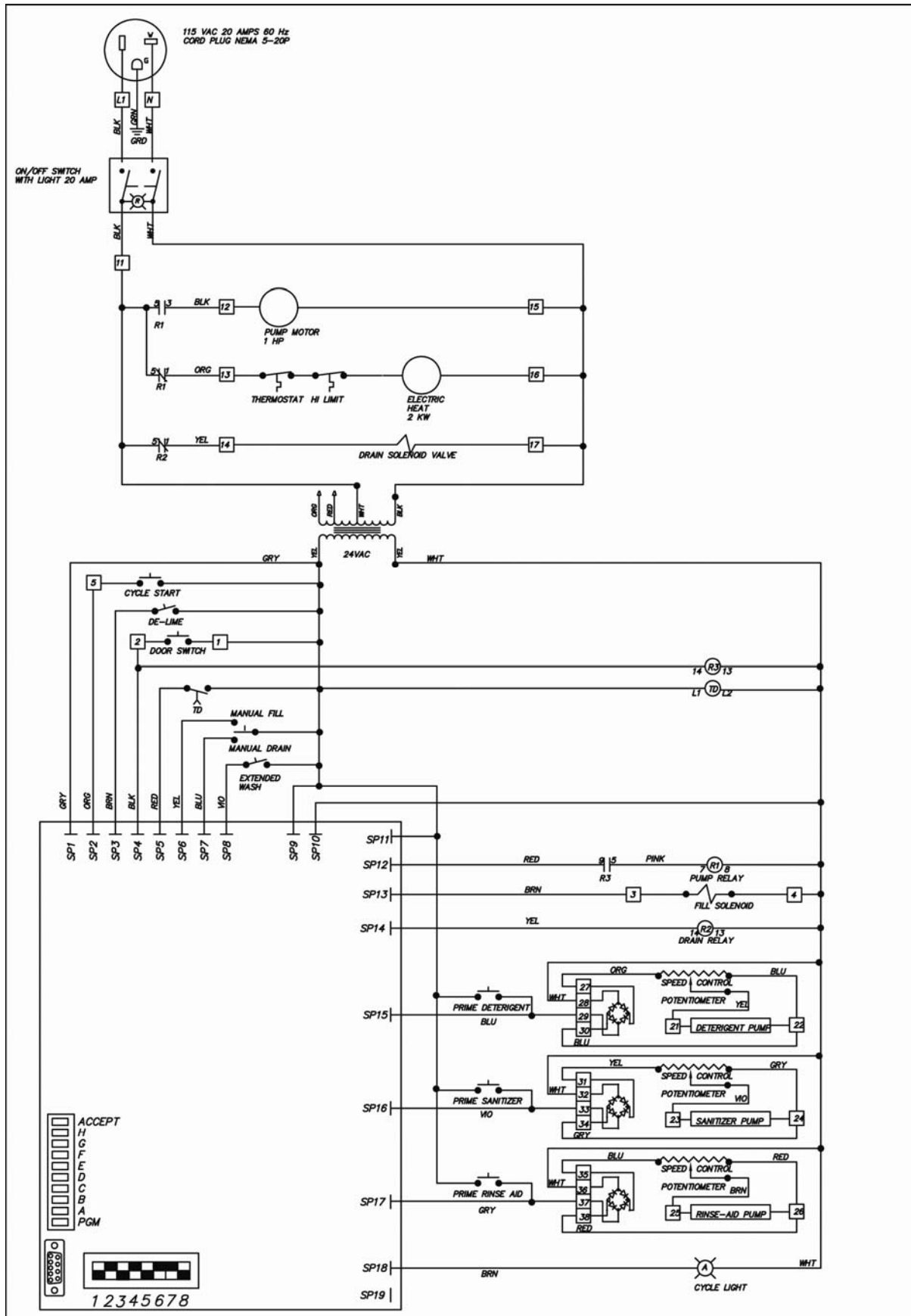



Insinger Machine Company
6245 State Road
Philadelphia, PA 19135-2996

800.344.4802

Fax 215.624.6966

www.insingermachine.com