

SIMPLI-FLEX®2000

COUNTER/CABINET MOUNT DISPENSERS

FOR IN-COUNTER MOUNTING:

REFER TO CHART AND DIAGRAM BELOW TO ESTABLISH MOUNTING HOLE SIZE AND MINIMUM CLEARANCE FOR EASE OF INSTALLATION AND SERVICE. ALLOW AT LEAST 1/4" (6.35 mm) BETWEEN DISPENSERS (DIMENSION "A")

1. Lay out and cut hole(s) for dispenser.
2. Remove gasket (2), pusher (3), and spring (4). (See Figure 1)
3. Pre-drill holes for #8 x 3/4" mounting screws (5). Slide dispenser into hole and secure through keyhole slots with screws and studs (7) provided. (See Figure 2)
4. Reassemble dispenser. Clamp ring (1) is installed over the gasket (2) as last step in reassembly. (See Figure 1)

LOADING THE DISPENSER:

Your Modular SIMPLI-FLEX® dispenser is completely self-adjusting and can dispense virtually any size or shape of cup!

1. Unwrap cups and gently push into completely assembled dispenser tube, BOTTOM OF CUP FACING OUT. (See Figure 3)

CLEANING THE DISPENSER:

Your Modular SIMPLI-FLEX® dispenser is designed to provide an easy means of dispensing. The dispenser can be disassembled using only a phillips screwdriver to make regular cleaning simple and painless! Please clean dispenser before use. Regular cleaning will prolong the life of the dispenser, keep it looking new and ensure sanitary dispensing.

1. Remove clamp ring (1), screws (5), and studs (7), to remove dispenser from mounting location. (See Figure 2 illustration C thru A)
2. Remove gasket (2), pusher (3), and spring (4). (See Figure 1)
3. Clean clamp ring and gasket in hot, soapy water. Air dry. NOTE: these parts are dishwasher safe.
4. Rinse dispenser tube and wipe with a non-toxic cleaner/sanitizer.
5. Reassemble dispenser in reverse of above. (See Figure 2 illustration A thru C)

SIMPLI-FLEX®2000

COUNTER/CABINET MOUNT DISPENSERS

CATALOG NUMBER	APPLICATION	DESCRIPTION
1015023	Elevator type, counter/cabinet mount, for paper, plastic, foam cups	SF2000

SF2000	
INCHES (METRIC)	
A	6-3/4 (172mm)
B	23-1/32 (585mm)
C	5-1/4 (133mm)
D	5-1/2 (140mm)

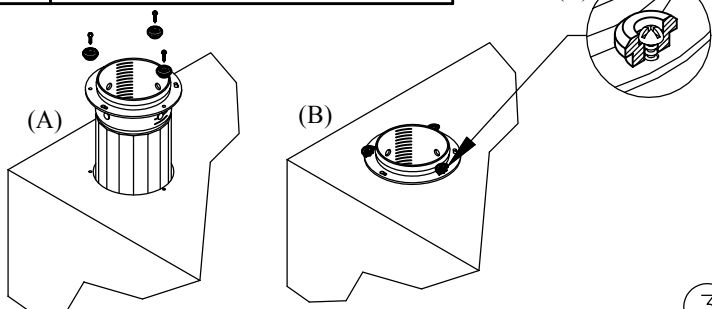
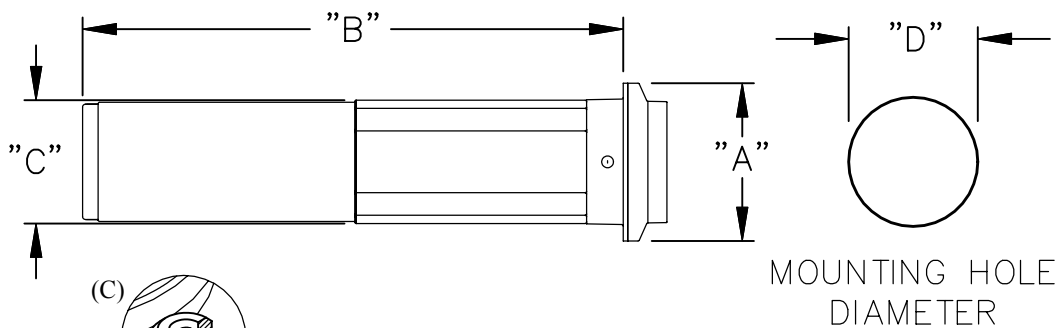

FIGURE 2

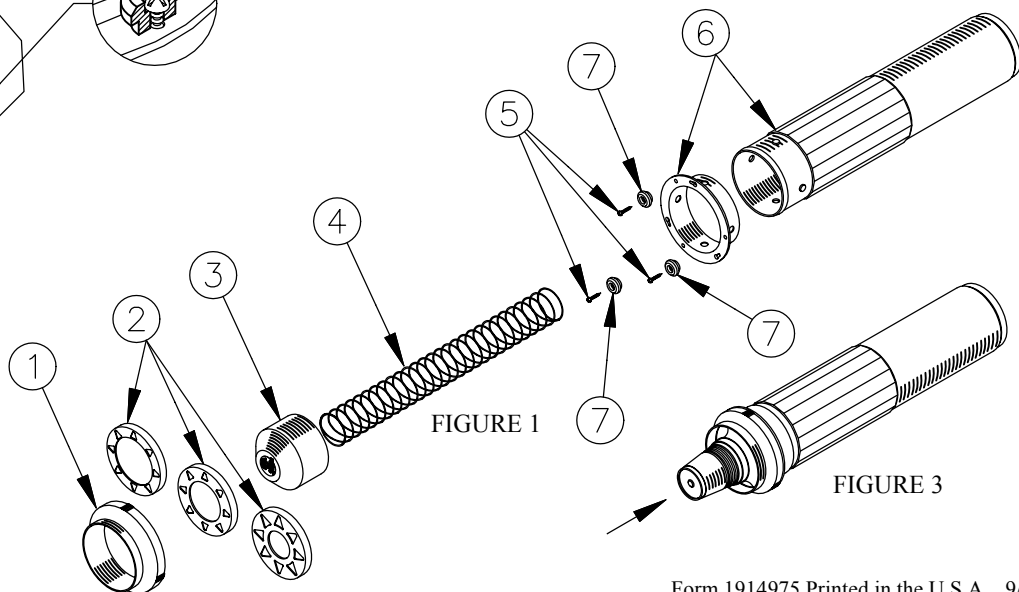

FIGURE 1

FIGURE 3

MODULAR DISPENSING SYSTEMS

DIVISION OF TOMLINSON INDUSTRIES
 13700 Broadway Ave.
 Cleveland Ohio 44125-1992
 Phone: 216/587-3400
 Fax: 216/587-0733
 www.tomlinsonind.com



World Class, Worldwide
 ©Tomlinson Industries 1999

SIMPLI-FLEX®2000

COUNTER/CABINET MOUNT DISPENSERS

FOR CABINET MOUNTING: (optional)

For reference to instructions below use exploded view of cup dispenser (See page 1 Figure 1).
We recommend that the dispenser be supported from the rear when used in horizontal applications.

PART 1: Disassemble

1. Remove gasket from lip of dispenser (See Figure 6 illustration B and C).
- NOTE: CAUTION when removing gasket, pusher may be under small amount of spring tension.
2. Remove pusher from spring (See Figure 6 illustration D and E).
3. Remove spring from dispenser (See Figure 6 illustration F and G).

PART 2: Assemble Mounting Hardware

1. Remove hardware from packet. Hardware kit consists of 1 - 10-32x1-3/4 slotted round head screw(1), 3 - 8-18x3/4 phillip head screw(2), 1 - 10-32 speed clip(3), and 3 - studs(7) (See Figure 7).
2. Grasp the head of the screw(1) with your hand and lead it inside the open end of dispenser to the bottom(See Figure 8 illustration I).
3. With screw(1) in hand, lead threads through hole in bottom of dispenser, ONLY threads of screw(1) will pass through this hole(See figure 8 illustration I).
4. While holding screw(1) firmly to the bottom from inside the dispenser, attach speed clip(3) by threading it on screw(1) as shown in figure 8 illustration J.
5. While continuing to holding screw(1) to the bottom, tighten speed clip(3) firmly to bottom of dispenser (See Figure 8 illustration K).
6. Reassemble dispenser in reverse order. Clamp ring is installed over the gasket as last step in reassembly. (See Figure 6 illustration G thru A)

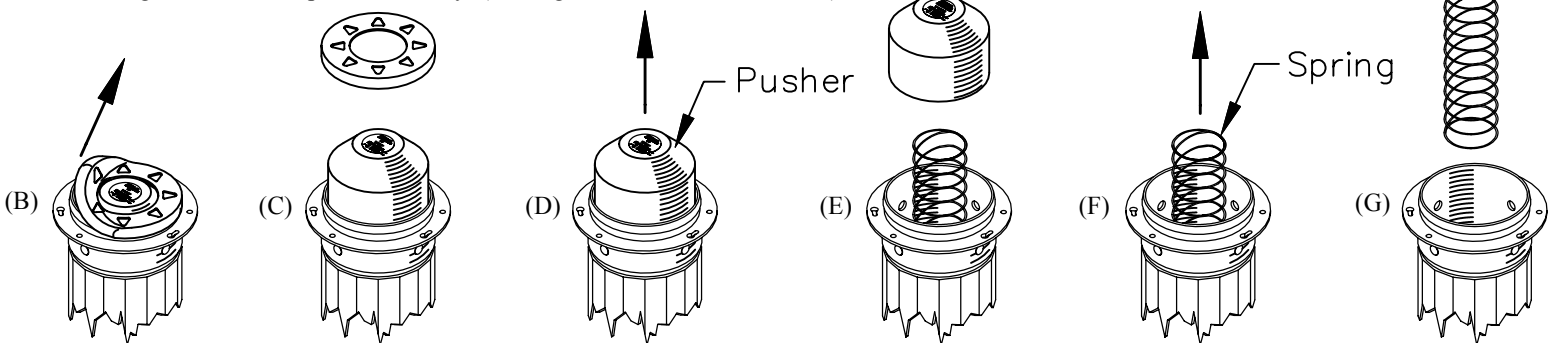
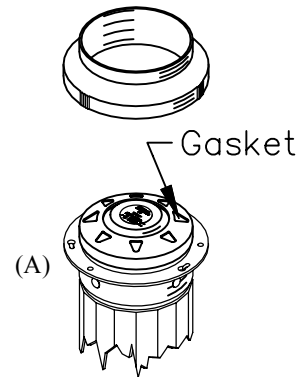

SIMPLI-FLEX 2000® ASSEMBLE CABINET MOUNTING HARDWARE

FIGURE 7

FIGURE 8

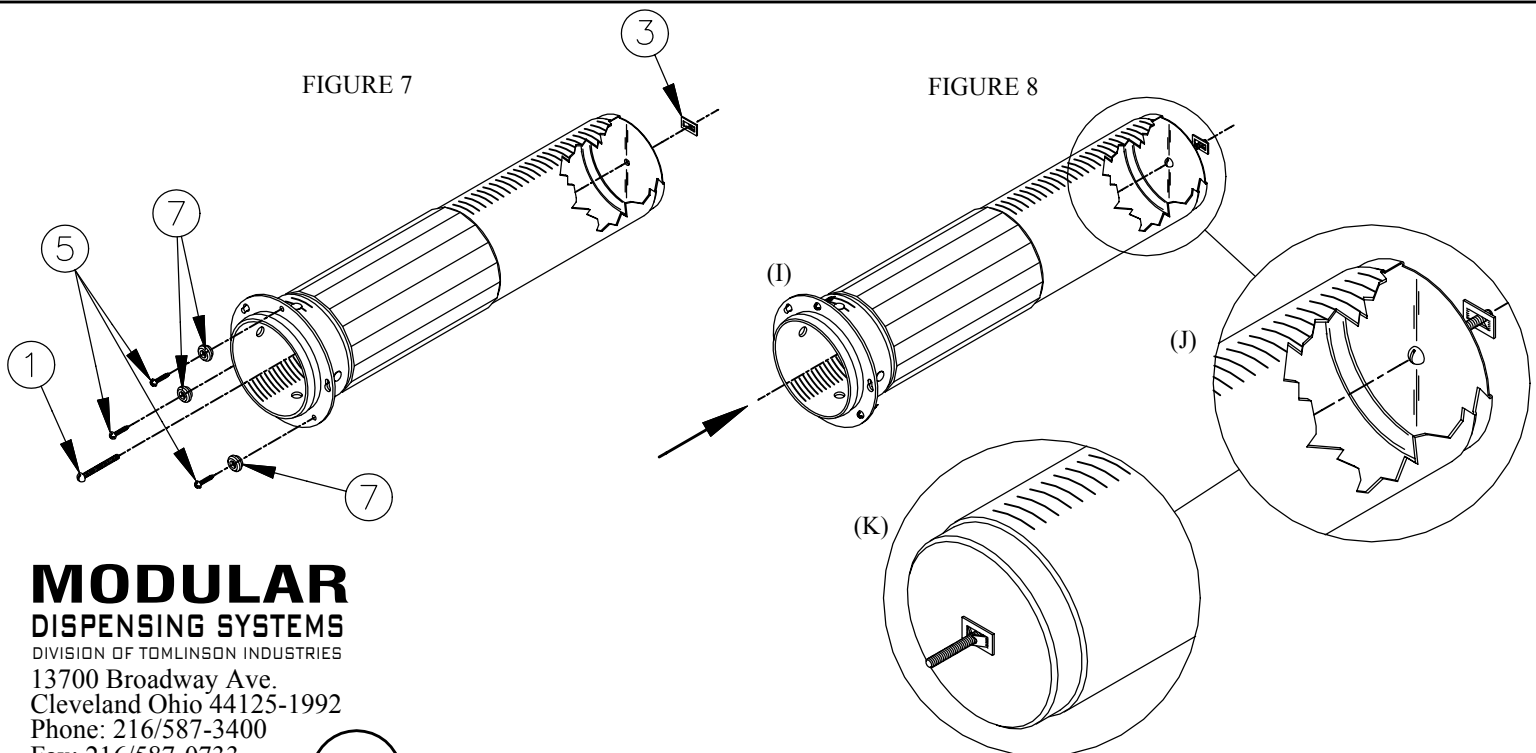

REVERSE ANGLE

Form 1914975 Printed in the U.S.A. 9/03
Patent Pending

MODULAR DISPENSING SYSTEMS

DIVISION OF TOMLINSON INDUSTRIES

13700 Broadway Ave.
Cleveland Ohio 44125-1992
Phone: 216/587-3400Fax: 216/587-0733
www.tomlinsonind.com

World Class, Worldwide

©Tomlinson Industries 1999



SIMPLI-FLEX® 2000

COUNTER/CABINET MOUNT DISPENSERS

CHANGING CUP SIZE:

For reference to instructions below use exploded view of cup dispenser (See page 1 figure 1).

1. Remove cup(s) from dispenser (See figure 4 illustration A and B).
2. Remove decorator clamp ring (See figure 4 illustration C and D).
3. Remove gasket from lip of dispenser (See figure 4 illustration E and F).
NOTE: CAUTION when removing gasket, pusher may be under small amount of spring tension.
4. Replace gasket with desired size (See Figure 5 reference chart at bottom of page).
5. Reassemble dispenser in reverse order (See figure 4 illustration F thru A)

FIGURE 4

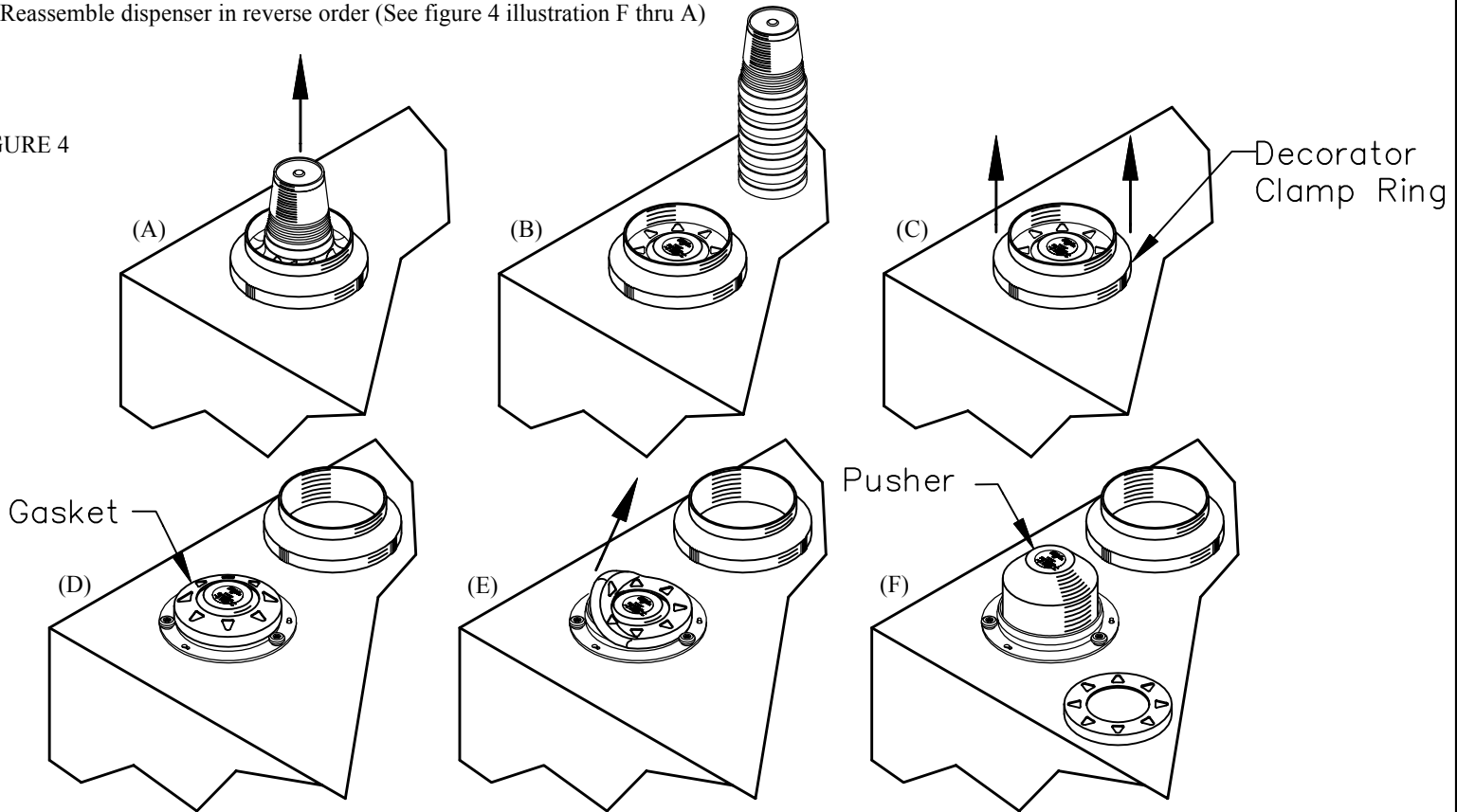

SIMPLI-FLEX 2000®

GASKET SIZE REFERENCE

FIGURE 5

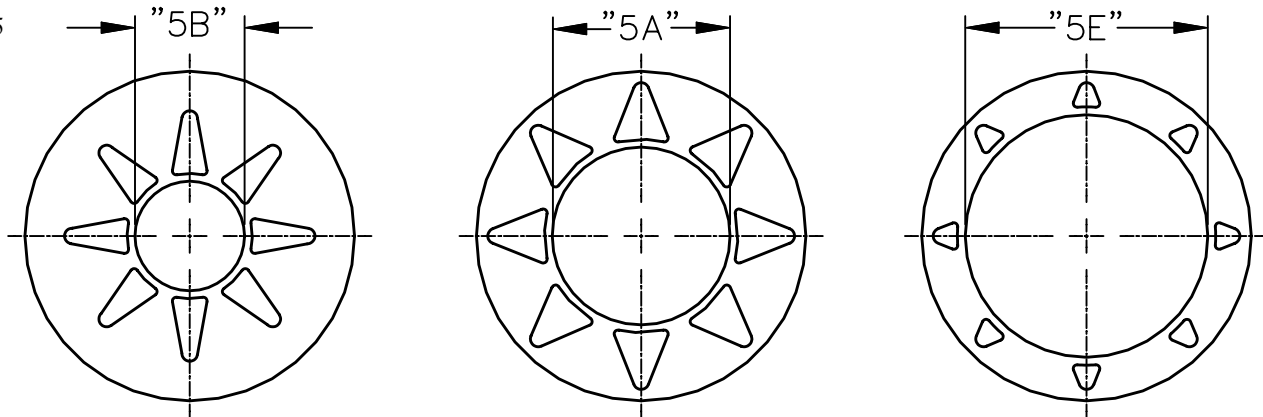

GASKET REFERENCE CHART

Dimension Letter:	"5B"	"5A"	"5E"
Cup Ounce:	3-1/2 oz. - 14 oz.	14 oz. - 32 oz.	32 oz. - 44 oz.
Cup Lip Diameter: (Metric)	2-1/4" - 3-7/8" (57mm - 98mm)	3-1/2" - 4-7/16" (89mm - 113mm)	4-1/4" - 4-5/8" (108mm - 117mm)

MODULAR
DISPENSING SYSTEMS
 DIVISION OF TOMLINSON INDUSTRIES
 13700 Broadway Ave.
 Cleveland Ohio 44125-1992
 Phone: 216/587-3400
 Fax: 216/587-0733
 www.tomlinsonind.com



World Class, Worldwide
 ©Tomlinson Industries 1999